

TEST REPORT

2023EC0149

DATE OF RECEPTION

Date Format: dd/MM/yyyy 06/04/2023

DATE TESTS

Starting: 12/04/2023

Ending: 28/04/2023

APPLICANT

BAYMAX KİŞİSEL KORUYUCU DONANIMLARI ÜR.
SAN. TİC.
YUNUS EMRE MAH. ULUBEY CAD. NO:10
ISTANBUL
Turkey

Att. Mert Tunalı

IDENTIFICATION AND DESCRIPTION OF SAMPLES

Reference by AITEX	Reference by customer	AITEX sample description
2023EC0149-S01	S-550	Spectacles

TESTS CARRIED OUT

- HEADBAND.
- DETERMINATION OF SPHERICAL, ASTIGMATIC AND PRISMATIC REFRACTIVE POWERS.
- DIFFUSION OF THE LIGHT.
- EVALUATION OF THE MATERIAL QUALITY AND SURFACE.
- INCREASED STRENGTH.
- VARIATION OF THE LUMINOUS TRANSMITTANCE.
- STABILITY AT HIGH TEMPERATURE.
- RESISTANCE TO UV RADIATION.
- RESISTANCE TO IGNITION.
- RESISTANCE TO THE IMPACT TO HIGH SPEED PARTICLES.
- RESISTANCE TO FOGGING.
- ASSESSMENT TEST VISUAL FIELD.
- EVALUATION OF LATERAL PROTECTION.
- VISIBLE AND ULTRAVIOLET TRANSMITTANCE.

Tests marked with * are not included within the scope of the ENAC accreditation.





DESCRIPTION OF SAMPLES

Reference by AITEX: 2023EC0149-S01

Reference by customer:

S-550

AITEX sample description:

Spectacles

AITEX Subsamples	Subsample Description
2023EC0149-S01.1	Goggles with clear lens
2023EC0149-S01.2	Goggles with anti-fog coating



EXECUTIVE SUMMARY

	Reference	Test/Standard	Result
EN 166:2001	2023EC0149-S01	HEADBAND EN 166:2001 Pto 6.3	PASS
		DETERMINATION OF SPHERICAL, ASTIGMATIC AND PRISMATIC REFRACTIVE POWERS EN 167:2001 Pto 3	CLASS 1
		INCREASED ROBUSTNESS EN 168:2001 Pto.3	PASS
		STABILITY AT HIGH TEMPERATURE EN 168:2001 Pto.5	PASS
		RESISTANCE TO IGNITION EN 168:2001 Pto.7	PASS
		RESISTANCE TO THE IMPACT TO HIGH SPEED PARTICLES EN 168:2001 Pto.9.2.1	MARKING F
		ASSESSMENT OF FIELD OF VISION EN 168:2001 Pto.18	PASS
		EVALUATION OF LATERAL PROTECTION EN 168:2001 Pto.19	PASS
EN 170:2002	2023EC0149-S01.1	DIFFUSION OF THE LIGHT EN 167:2001 Pto 4.2.2	PASS
		EVALUATION OF THE MATERIAL QUALITY AND SURFACE EN 167:2001 Pto.5	PASS
		VARIATION OF THE LUMINOUS TRANSMITTANCE EN 167:2001 Pto 7	PASS
		RESISTANCE TO UV RADIATION EN 168:2001 Pto.6 / EN 167:2001 Pto 4.2.2	PASS
EN 170:2002	2023EC0149-S01.2	DIFFUSION OF THE LIGHT EN 167:2001 Pto 4.2.2	PASS
		EVALUATION OF THE MATERIAL QUALITY AND SURFACE EN 167:2001 Pto.5	PASS
		VARIATION OF THE LUMINOUS TRANSMITTANCE EN 167:2001 Pto 7	PASS
EN 170:2002	2023EC0149-S01.1	VISIBLE AND ULTRAVIOLET TRANSMITTANCE EN 170:2002	CLASS 2C- 1,2
	2023EC0149-S01.2	VISIBLE AND ULTRAVIOLET TRANSMITTANCE EN 170:2002	CLASS 2C- 1,2



REQUIREMENT SUMMARY

HEADBAND

Requirement to be met according to the standard EN 166:2001 point 6.3

When the headband is used as the main fastening device, it shall be at least 10mm wide.

DETERMINATION OF SPHERICAL, ASTIGMATIC AND PRISMATIC REFRACTIVE POWERS

Requirements to assessment the spherical, astigmatic and prismatic refractive powers according to the standard EN 166:2001 point 7.1.2.1.2.

OPTICAL CLASS	SPHERICAL POWER (D_1+D_2)/2 (m^{-1})	ASTIGMATIC POWER $ D_1-D_2 $ (m^{-1})	PRISMATIC POWERS IMBALANCE cm/m		
			Horizontal		Vertical
			Base out	Base in	
1	$\pm 0,06$	0,06	0,75	0,25	0,25
2	$\pm 0,12$	0,12	1,00	0,25	0,25
3	+ 0,12 - 0,25	0,25	1,00	0,25	0,25

DIFFUSION OF THE LIGHT

Requirements for the evaluation of the diffusion light for eye protectors according to standard EN 166:2001 (point 7.1.2.3).

Maximum value of reduced luminance factor according to EN 166:2001 point 7.1.2.3

Reduced luminance factor	Welding filters	Oculars for protection against high-speed particles	Other ocular
($cd / m^2 * lx$)	1,00	0,75	0,50

EVALUATION OF THE MATERIAL QUALITY AND SURFACE

Requirements for the evaluation of the quality of the material and surface of the eye protector according to standard EN 166:2001 (point 7.1.3).

Except for a 5 mm wide marginal band, the eyepieces must be free of any significant defect that may alter vision during use, such as bubbles, scratches, inclusions, spots, pitting, mold marks, threads, roughness, peeling, slits and ripples.



INCREASED ROBUSTNESS

Requirements of the test of increased strength for eye protectors according to standard EN 166:2001 (point 7.1.4.2.2)

After the test should not occur:

Fracture of the ocular	Deformation of the ocular	Fracture of the ocular rim or mount	Failure in lateral protection
------------------------	---------------------------	-------------------------------------	-------------------------------

VARIATION OF THE LUMINOUS TRANSMITTANCE

Requirement to assess the uniformity of luminous transmittance in eye protectors according to the standard EN 166:2001 (point 7.1.2.2.3).

- The relative variations in the value of the luminous transmittance (τ_V) around the road centers shall not exceed the values in the table.
- The relative deviation between the two visual centers of the right and left eyepieces should not exceed the values in the table or 20%, taking the greater value.

Luminous transmittance τ_V (%)		Admissible relative variation $\Delta\tau$ (%)
Lower than	Till	
100	17.8	± 5
17.8	0.44	± 10
0.44	0.023	± 15
0.023	0.0012	± 20
0.0012	0.000023	± 30

STABILITY AT HIGH TEMPERATURE

Requirement to be met according to the standard EN 166:2001 point 7.1.5.1

Full protectors shall not show apparent deformation.

RESISTANCE TO UV RADIATION

Requirements for the evaluation of the diffusion light for eye protectors according to standard EN 166:2001 (point 7.1.2.3) and EN 166: 2001 (point 7.1.5.2).

Maximum value of reduced luminance factor according to EN 166:2001 point 7.1.2.3



The relative variations in the value of the luminous transmittance (τ_V) shall not exceed the values in the table.

Reduced luminance factor	Welding filters	Oculars for protection against high-speed particles	Other ocular
cd / m ² lx	1.00	0.75	0.50

Luminous transmittance τ_V (%)		Admissible relative variation (%)
Lower than	Till	
100	17.8	±5
17.8	0.44	±10
0.44	0.023	±15
0.023	0.0012	±20
0.0012	0.000023	±30

RESISTANCE TO IGNITION

Requirement to be met according to the standard EN 166:2001 point 7.1.7.

No part of the ocular protector ignites or continues to glow after the steel rod has been removed.

RESISTANCE TO THE IMPACT TO HIGH SPEED PARTICLES

Requirements of the test of resistance against particle impacts at high speed for eye protectors according to standard EN 166:2001 (point 7.2.2).

Fracture of the ocular	Deformation of the ocular	Fracture of the ocular rim or mount	Failure in lateral protection
------------------------	---------------------------	-------------------------------------	-------------------------------

ASSESSMENT OF FIELD OF VISION

Requirements for the evaluation of the field of vision for eye-protector according to standard EN 166:2001 (point 7.1.1).

The eye protectors shall have, at least, a field of vision defined by the two ellipses of Figure 1 of the standard when placed and centred at a distance of 25 mm from the surface of the eyes of the appropriate test head. The axis Horizontal should be parallel to, and 0.7 mm below, the line connecting the centres of both eyes. The ellipses must have a horizontal width of 22.0 mm and a vertical width of 20.0 mm. The distance between centres of the two ellipses should be $d = c + 6$ mm, where c is the interpupillary distance. The interpupillary distance of the head is 64 mm and the small test head is 54 mm, if the manufacturer does not indicate otherwise.

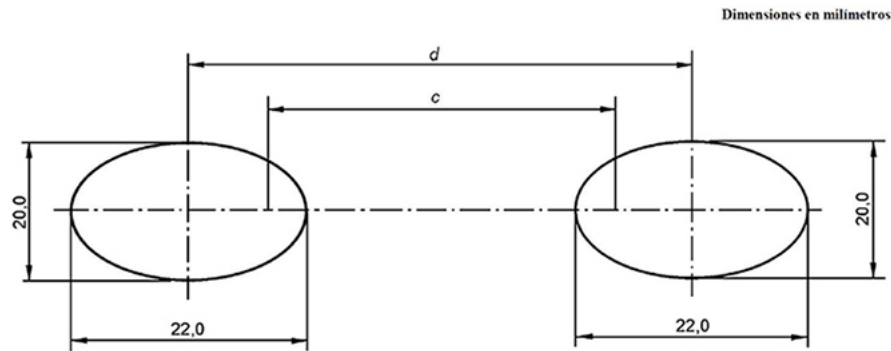

EVALUATION OF LATERAL PROTECTION

Requirements for the evaluation of the lateral protection for eye protectors according to standard EN 166:2001 (point 7.2.8)

The lateral protection shall prevent contact between the end of the rod and the impact areas of the test head.

VISIBLE AND ULTRAVIOLET TRANSMITTANCE

Requirements for the evaluation of the visible and ultraviolet transmittance for eye protectors according to the standards EN 166:2001 (point 6) and EN 170: 2002 (point 5).

Protection class	Maximum spectral transmittance in UV $\tau(\lambda)$		Visible transmission coefficient τ_v	
	313 nm %	365 nm %	Maximum %	Minimum %
2-1.2	0.0003	10	100	74.4
2-1.4	0.0003	9	74.4	58.1
2-1.7	0.0003	7	58.1	43.2
2-2	0.0003	5	43.2	29.1
2-2.5	0.0003	3	29.1	17.8
2-3	0.0003	2	17.8	8.5
2-4	0.0003	0.8	8.5	3.2
2-5	0.0003	0.3	3.2	1.2

Additional requirements:

- For $210 \text{ nm} \leq \lambda \leq 313 \text{ nm}$, spectral transmittance shall not be greater than specified value for 313 nm;
- For $313 \text{ nm} < \lambda \leq 365 \text{ nm}$, spectral transmittance shall not be greater than specified value for 365 nm;
- For $365 \text{ nm} < \lambda \leq 405 \text{ nm}$, spectral transmittance shall not be greater than visible transmittance coefficient.

Eyepieces with enhanced color recognition (optional):

- For wavelengths between 500 nm and 650 nm, the spectral transmittance coefficient shall not be lower than $0.2 \tau_v$;
- The relative visual attenuation coefficient Q, for red, yellow, green and blue signal light shall not be lower than 0.8.

**SAMPLE/S DESCRIPTION**

AITEK Reference	Description of the sample
2023EC0149-S01	Goggles with clear lens, clear frame and black headband



///



RESULTS

HEADBAND

Standard

EN 166:2001 (point 6.3)

Apparatus

Vernier calliper

Test date

27/04/2023

Uncertainty

The expanded uncertainty is $\pm 0,1$ mm of the value of the measured for a probability of coverage of 95%.

Reference

2023EC0149-S01

Sample no.	Headband (mm)
1	39
2	40
3	40

The test was carried out at APPE Laboratory located at Polígono Industrial Santiago Payá C/ Filá Benimerines, 25 B – 03801 Alcoy (Alicante).

///



RESULTS

DETERMINATION OF SPHERICAL, ASTIGMATIC AND PRISMATIC REFRACTIVE POWERS

Standard

EN 167:2001 (point 3.2)

Apparatus

Refractive powers test equipment

Ambient condition test

Date test	Initial	Final
18/04/2023	20 °C	20,9 °C

Uncertainty

The expanded uncertainty is $\pm 5\%$ of the value of the measurand for a probability of coverage of 95%.

Reference

2023EC0149-S01

Specimen no.	Spherical power (D)	Astigmatic power (D)
1 R	-0,02	0,00
1 L	-0,02	0,00
2 R	-0,02	0,00
2 L	-0,03	0,00
3 R	-0,03	0,01
3 L	-0,02	0,01

R: right eye - L: left eye

Type of prismatic effect

Base Out

Specimen no.	Horizontal prism imbalance (cm/m)	Vertical prism imbalance (cm/m)
1	0,18	0,05
2	0,23	0,05
3	0,25	0,05

The test was carried out at APPE Laboratory located at Polígono Industrial Santiago Payá C/ Filá Benimerines, 25 B – 03801 Alcoy (Alicante).

///



RESULTS

DIFFUSION OF THE LIGHT

Standard

EN 167:2001 (point 4.2.2)

Apparatus

Diffusion light equipment

Test room conditions for testing

Test date	Initial	Final
19/04/2023	18,7 °C	22 °C

Uncertainty

The expanded uncertainty is $\pm 4\%$ of the value of the measurand for a probability of coverage of 95%.

Reference

2023EC0149-S01.1

Specimen no.	Reduced luminance factor ($\text{cd} \cdot \text{m}^{-2} \cdot \text{lx}^{-1}$)
1 R	0,05
1 L	-0,02
2 R	-0,21
2 L	0,08
3 R	0,26
3 L	0,04

R: Right eye - L: Left eye

The test was carried out at APPE Laboratory located at Polígono Industrial Santiago Payá C/ Filá Benimerines, 25 B – 03801 Alcoy (Alicante).

///



RESULTS

DIFFUSION OF THE LIGHT

Standard

EN 167:2001 (point 4.2.2)

Apparatus

Diffusion light equipment

Test room conditions for testing

Test date	Initial	Final
19/04/2023	18,7 °C	22,8 °C

Uncertainty

The expanded uncertainty is $\pm 4\%$ of the value of the measurand for a probability of coverage of 95%.

Reference

2023EC0149-S01.2

Specimen no.	Reduced luminance factor ($\text{cd} \cdot \text{m}^{-2} \cdot \text{lx}^{-1}$)
1 R	0,05
1 L	0,08
2 R	0,14
2 L	0,06
3 R	0,03
3 L	0,09

R: Right eye - L: Left eye

The test was carried out at APPE Laboratory located at Polígono Industrial Santiago Payá C/ Filá Benimerines, 25 B – 03801 Alcoy (Alicante).

///



RESULTS

EVALUATION OF THE MATERIAL QUALITY AND SURFACE

Standard

EN 167:2001 (point 5)

Test date

19/04/2023

Apparatus

Illuminated grid

Reference

2023EC0149-S01.1

Sample no.	It is appreciated any significant defect in the eyepieces
1	NO
2	NO
3	NO

The test was carried out at APPE Laboratory located at Polígono Industrial Santiago Payá C/ Filá Benimerines, 25 B – 03801 Alcoy (Alicante).

///



RESULTS

EVALUATION OF THE MATERIAL QUALITY AND SURFACE

Standard

EN 167:2001 (point 5)

Test date

19/04/2023

Apparatus

Illuminated grid

Reference

2023EC0149-S01.2

Sample no.	It is appreciated any significant defect in the eyepieces
1	NO
2	NO
3	NO

The test was carried out at APPE Laboratory located at Polígono Industrial Santiago Payá C/ Filá Benimerines, 25 B – 03801 Alcoy (Alicante).

///



RESULTS

INCREASED STRENGTH

Standard

EN 168:2001 (point 3)

Apparatus

Equipment of steel ball fall

Test date

12/04/2023

Test room conditions for testing

Initial temperature	Final temperature
22,6 °C	23 °C

Sample pre-conditioning

- Samples 1, 2, 3, 4, 5 y 6: conditioning at a temperature of (55 ± 2) ° C for at least 1 h.
- Samples 7, 8, 9,10, 11 and 12: conditioning at a temperature of (-5 ± 2) ° C for at least 1 h.

Reference

2023EC0149-S01

FRONTAL IMPACT, RIGHT OCULAR				
It is appreciated				
Sample no.	Ocular fracture	Ocular deformation	Fracture of the frame	Failure in lateral protection
1	NO	NO	NO	NO
2	NO	NO	NO	NO
7	NO	NO	NO	NO
8	NO	NO	NO	NO

>>>



FRONTAL IMPACT, LEFT OCULAR				
It is appreciated				
Sample no.	Ocular fracture	Ocular deformation	Fracture of the frame	Failure in lateral protection
3	NO	NO	NO	NO
4	NO	NO	NO	NO
9	NO	NO	NO	NO
10	NO	NO	NO	NO

LATERAL IMPACT, RIGHT OCULAR				
It is appreciated				
Sample no.	Ocular fracture	Ocular deformation	Fracture of the frame	Failure in lateral protection
5	NO	NO	NO	NO
11	NO	NO	NO	NO

LATERAL IMPACT, LEFT OCULAR				
It is appreciated				
Sample no.	Ocular fracture	Ocular deformation	Fracture of the frame	Failure in lateral protection
6	NO	NO	NO	NO
12	NO	NO	NO	NO

The test was carried out at APPE Laboratory located at Polígono Industrial Santiago Payá C/ Filá Benimerines, 25 B – 03801 Alcoy (Alicante).

///



RESULTS

VARIATION OF THE LUMINOUS TRANSMITTANCE

Standard

EN 167:2001 (point 7)

Apparatus

Equipment for uniformity of transmittance measurement

Test date

25/04/2023

UncertaintyThe expanded uncertainty is $\pm 3\%$ of the value of the measurand for a probability of coverage of 95%.**Reference**

2023EC0149-S01.1

Sample no.	Right ocular ΔT (%)	Left ocular ΔT (%)	Between both oculars ΔT (%)
1	0,6	0,9	0,2
2	1,9	1,5	0,8
3	1,6	1	0,3

R: Right eye; L: Left eye

The test was carried out at APPE Laboratory located at Polígono Industrial Santiago Payá C/ Filá Benimerines, 25 B – 03801 Alcoy (Alicante).

///



RESULTS

VARIATION OF THE LUMINOUS TRANSMITTANCE

Standard

EN 167:2001 (point 7)

Apparatus

Equipment for uniformity of transmittance measurement

Test date

25/04/2023

UncertaintyThe expanded uncertainty is $\pm 3\%$ of the value of the measurand for a probability of coverage of 95%.**Reference**

2023EC0149-S01.2

Sample no.	Right ocular ΔT (%)	Left ocular ΔT (%)	Between both oculars ΔT (%)
1	0,8	1,1	0,3
2	1,7	1,2	0,5
3	1,7	1,1	0,4

R: Right eye; L: Left eye

The test was carried out at APPE Laboratory located at Polígono Industrial Santiago Payá C/ Filá Benimerines, 25 B – 03801 Alcoy (Alicante).

///



RESULTS

STABILITY AT HIGH TEMPERATURE

Standard

EN 168:2001 (point 5)

Apparatus

Forced air stove

testing date

12/04/2023

Sample conditioning

Samples 1, 2 and 3: conditioning at a temperature of $(55 \pm 2) ^\circ \text{C}$ for (60 ± 5) min + stabilize at $(23 \pm 5) ^\circ \text{C}$ during 60 min.

Reference

2023EC0149-S01

Sample no.	Deformation observed in the ocular protector
1	NO
2	NO
3	NO

The test was carried out at APPE Laboratory located at Polígono Industrial Santiago Payá C/ Filá Benimerines, 25 B – 03801 Alcoy (Alicante).

///



RESULTS

RESISTANCE TO UV RADIATION

DIFFUSION OF THE LIGHT

Standard

EN 168:2001 (point 6) and EN 167:2001 (point 4.2.2)

Apparatus

Diffusion light equipment

Start test date

28/04/2023

End test date

28/04/2023

Sample conditioning

Samples 1, 2 and 3: UV ageing conditioning (50 h \pm 0.2 h).

Uncertainty

The expanded uncertainty is ± 4 % of the value of the measurand for a probability of coverage of 95%.

Reference

2023EC0149-S01.1

Sample No	Reduced luminance factor (cd / m ² * lx)
1 R	0,44
2 L	0,10
3 R	0,10

The test was carried out at APPE Laboratory located at Polígono Industrial Santiago Payá C/ Filá Benimerines, 25 B – 03801 Alcoy (Alicante).

>>>



TRANSMITTANCE

Standard

EN 168:2001 (point 6) and EN 167:2001 (point 6)

Start test date

28/04/2023

End test date

28/04/2023

Apparatus

Ocular spectrophotometer.

Sample Conditioning

Samples 1, 2 and 3: UV ageing conditioning (50 h \pm 0.2 h).

Uncertainty

The expanded uncertainty is ± 3 % of the value of the measurand for a probability of coverage of 95%.

Reference

2023EC0149-S01.1

Sample no.	Luminous transmittance T_v (380 nm – 780 nm) %	Luminous transmittance after the UV treatment T_v (380 nm – 780 nm) %	Relative variation (%)
1 R	87,1	87,2	0,1
2 L	87,0	88,0	1,2
3 R	86,0	87,2	1,4

R: Right eye - L: Left eye

The test was carried out at APPE Laboratory located at Polígono Industrial Santiago Payá C/ Filá Benimerines, 25 B – 03801 Alcoy (Alicante).

///



RESULTS

RESISTANCE TO IGNITION

Standard

EN 168:2001 (point 7)

Apparatus

Steel rod of 300 mm, thermocouple type K with multifunction equipment and ignition equipment.

Test date

20/04/2023

Test room conditions for testing

Initial temperature	Final temperature
18,4 °C	18,8 °C

Reference

2023EC0149-S01

After the steel rod removal, the ocular protector ignites or continues to glow

Sample no.	Lens	Anti-fog lens	Black pieces	Frame
1	NO	NO	NO	NO
2	NO	NO	NO	NO
3	NO	NO	NO	NO

The test was carried out at APPE Laboratory located at Polígono Industrial Santiago Payá C/ Filá Benimerines, 25 B – 03801 Alcoy (Alicante).

///



RESULTS

RESISTANCE TO THE IMPACT TO HIGH SPEED PARTICLES

Standard

EN 168:2001 (point 9)

Apparatus

Equipment propeller steel ball

Date test

25/04/2023

Test room conditions for testing

Initial	Final
22,1 °C	23,5 °C

Speed impact

45 m/s

Reference

2023EC0149-S01

FRONTAL IMPACT, RIGHT OCULAR				
It is appreciated				
Sample no.	Ocular fracture	Ocular deformation	Fracture of the frame	Failure in lateral protection
1	NO	NO	NO	NO
2	NO	NO	NO	NO
7	NO	NO	NO	NO
8	NO	NO	NO	NO

FRONTAL IMPACT, LEFT OCULAR				
It is appreciated				
Sample no.	Ocular fracture	Ocular deformation	Fracture of the frame	Failure in lateral protection
3	NO	NO	NO	NO
4	NO	NO	NO	NO
9	NO	NO	NO	NO
10	NO	NO	NO	NO

>>>



LATERAL IMPACT				
It is appreciated				
Sample no.	Ocular fracture	Ocular deformation	Fracture of the frame	Failure in lateral protection
5 R	NO	NO	NO	NO
6 L	NO	NO	NO	NO
11 R	NO	NO	NO	NO
12 L	NO	NO	NO	NO

R: Right eye - L: Left eye

The test was carried out at APPE Laboratory located at Polígono Industrial Santiago Payá C/ Filá Benimerines, 25 B – 03801 Alcoy (Alicante).

///



RESULTS

RESISTANCE TO FOGGING

Standard

EN 168:2001 (point 16)

Apparatus

Fogging equipment

Date test

27/04/2023

Test room conditions for testing

Initial temperature	Final temperature
22,5 °C	22,5 °C

Sample conditioning1h-2h submerged in distilled water at (23 ± 5) °C, then at least 12h at (23 ± 5) °C and 50% RH for drying.**Uncertainty**The expanded uncertainty is ± 3 % of the value of the measurand for a probability of coverage of 95%.**Reference**

2023EC0149-S01.2

Sample no.	Transmission factor (%) at 8 s
1	2
2	12
3	15
4	22

The test was carried out at APPE Laboratory located at Polígono Industrial Santiago Payá C/ Filá Benimerines, 25 B – 03801 Alcoy (Alicante).

///



RESULTS

ASSESSMENT TEST VISUAL FIELD

Standard

EN 168:2001 (point 18)

Test date

19/04/2023

Apparatus

Field of vision measurement equipment

Reference

2023EC0149-S01

Sample no.	Laser reaches some of the edges of the ocular protector
1	NO
2	NO
3	NO

The test was carried out at APPE Laboratory located at Polígono Industrial Santiago Payá C/ Filá Benimerines, 25 B – 03801 Alcoy (Alicante).

///



RESULTS

EVALUATION OF LATERAL PROTECTION

Standard

EN 168:2001 (point 19)

Apparatus

Steel rod of 125 mm

Test date

27/04/2023

Reference

2023EC0149-S01

Sample no.	Contact of the rod on the impact zones of the test head
1	NO
2	NO
3	NO

The test was carried out at APPE Laboratory located at Polígono Industrial Santiago Payá C/ Filá Benimerines, 25 B – 03801 Alcoy (Alicante).

///



RESULTS

VISIBLE AND ULTRAVIOLET TRANSMITTANCE

Standard

EN 167:2001 (point 6) and EN 170:2002

Apparatus

Ocular spectrophotometer

Test date

26/04/2023

Observation or deviation of the standard

The test is carried out using a filter to neutralize the fluorescence phenomenon that the sample presents.

Uncertainty

The expanded uncertainty is $\pm 3\%$ of the value of the measurand for a probability of coverage of 95%.

Reference

2023EC0149-S01.1

Sample no.	Luminous transmittance $T_V(380 \text{ nm} - 780 \text{ nm}) \%$
1 R	87,1
1 L	86,9
2 R	85,1
2 L	87,0
3 R	86,0
3 L	87,4

R: Right eye - L: Left eye

>>>



Sample no.	Range	Spectral transmittance $T_{(\lambda)}$ %	Relative visual attenuation quotient (Q)
1 R	210 nm $\leq \lambda \leq$ 313 nm	0,0002	$\geq 0,8$
	313 nm $\leq \lambda \leq$ 365 nm	0,0	
	365 nm $\leq \lambda \leq$ 405 nm	57,5	
	500 nm $\leq \lambda \leq$ 650 nm	86,6	
1 L	210 nm $\leq \lambda \leq$ 313 nm	0,0001	$\geq 0,8$
	313 nm $\leq \lambda \leq$ 365 nm	0,0	
	365 nm $\leq \lambda \leq$ 405 nm	56,5	
	500 nm $\leq \lambda \leq$ 650 nm	86,5	
2 R	210 nm $\leq \lambda \leq$ 313 nm	0,0001	$\geq 0,8$
	313 nm $\leq \lambda \leq$ 365 nm	0,0	
	365 nm $\leq \lambda \leq$ 405 nm	57,3	
	500 nm $\leq \lambda \leq$ 650 nm	84,6	
2 L	210 nm $\leq \lambda \leq$ 313 nm	0,0001	$\geq 0,8$
	313 nm $\leq \lambda \leq$ 365 nm	0,0	
	365 nm $\leq \lambda \leq$ 405 nm	57,6	
	500 nm $\leq \lambda \leq$ 650 nm	86,4	
3 R	210 nm $\leq \lambda \leq$ 313 nm	0,0002	$\geq 0,8$
	313 nm $\leq \lambda \leq$ 365 nm	0,0	
	365 nm $\leq \lambda \leq$ 405 nm	55,2	
	500 nm $\leq \lambda \leq$ 650 nm	85,5	
3 L	210 nm $\leq \lambda \leq$ 313 nm	0,0001	$\geq 0,8$
	313 nm $\leq \lambda \leq$ 365 nm	0,0	
	365 nm $\leq \lambda \leq$ 405 nm	54,4	
	500 nm $\leq \lambda \leq$ 650 nm	86,8	

R: Right eye - L: Left eye

///



RESULTS

VISIBLE AND ULTRAVIOLET TRANSMITTANCE

Standard

EN 167:2001 (point 6) and EN 170:2002

Apparatus

Ocular spectrophotometer

Test date

26/04/2023

Observation or deviation of the standard

The test is carried out using a filter to neutralize the fluorescence phenomenon that the sample presents.

Uncertainty

The expanded uncertainty is $\pm 3\%$ of the value of the measurand for a probability of coverage of 95%.

Reference

2023EC0149-S01.2

Sample no.	Luminous transmittance $T_v(380 \text{ nm} - 780 \text{ nm}) \%$
1 R	88,2
1 L	90,1
2 R	88,5
2 L	90,4
3 R	89,5
3 L	90,4

R: Right eye - L: Left eye

>>>



Sample no.	Range	Spectral transmittance $T_{(\lambda)}$ %	Relative visual attenuation quotient (Q)
1 R	210 nm \leq λ \leq 313 nm	0,0001	$\geq 0,8$
	313 nm \leq λ \leq 365 nm	0,0	
	365 nm \leq λ \leq 405 nm	56,5	
	500 nm \leq λ \leq 650 nm	87,4	
1 L	210 nm \leq λ \leq 313 nm	0,0001	$\geq 0,8$
	313 nm \leq λ \leq 365 nm	0,0	
	365 nm \leq λ \leq 405 nm	54,7	
	500 nm \leq λ \leq 650 nm	89,1	
2 R	210 nm \leq λ \leq 313 nm	0,0001	$\geq 0,8$
	313 nm \leq λ \leq 365 nm	0,0	
	365 nm \leq λ \leq 405 nm	57,3	
	500 nm \leq λ \leq 650 nm	87,3	
2 L	210 nm \leq λ \leq 313 nm	0,0002	$\geq 0,8$
	313 nm \leq λ \leq 365 nm	0,0	
	365 nm \leq λ \leq 405 nm	55,5	
	500 nm \leq λ \leq 650 nm	89,0	
3 R	210 nm \leq λ \leq 313 nm	0,0001	$\geq 0,8$
	313 nm \leq λ \leq 365 nm	0,0	
	365 nm \leq λ \leq 405 nm	57,2	
	500 nm \leq λ \leq 650 nm	88,9	
3 L	210 nm \leq λ \leq 313 nm	0,0002	$\geq 0,8$
	313 nm \leq λ \leq 365 nm	0,0	
	365 nm \leq λ \leq 405 nm	57,3	
	500 nm \leq λ \leq 650 nm	89,2	

R: Right eye - L: Left eye

///



Jorge Beltrá
Head of Advanced Personal Protective Equipments Lab



Date: 28/04/2023 14:13:10

Digitally Signed by:JORGE BELTRA BONILLO -

NIF:20051852S

LIABILITY CLAUSES

- 1.- AITEX is liable only for the results of the methods of analysis used, as expressed in the report and referring exclusively to the materials or samples indicated in the same which are in its possession, the professional and legal liability of the Centre being limited to these. Unless otherwise stated, the samples were freely chosen and sent by the applicant.
- 2.- AITEX shall not be liable in any case of misuse of the test materials nor for undue interpretation or use of this document
- 3.- The Offer and / or Order to which the applicant gives approval through signature and seal, constitutes the Legally Executable Agreement in which AITEX is responsible for safeguarding and guaranteeing the absolute confidentiality of the management of all the information obtained or created during the performance of the contracted activities.
- 4.- In the eventuality of discrepancies between reports, a check to settle the same will be carried out in the head offices of AITEX. Also, the applicants undertake to notify AITEX of any complaint received by them as a result of the report, exempting this Centre from all liability if such is not done, the periods of conservation of the samples being taken into account.
- 5.- AITEX will provide at the request of the person concerned, the treatment of complaints procedure. In the event that you want to make it, direct it to: calidad@aitex.es.
- 6.- AITEX is not responsible for the information provided by customers, which is reflected in the Report, and may affect the validity of the results.
- 7.- AITEX is not responsible for an inadequate state of the sample received that could compromise the validity of the results, expressing such circumstance, in the test reports.
- 8.- AITEX may include in its reports, analyses, results, etc., any other evaluation which it considers necessary, even when it has not been specifically requested.
- 9.- When a Declaration of Conformity is requested, if not indicated otherwise, the decision rule according to ILAC-G8: 2009 will be applied with a security zone of 1U and a Probability of False Acceptance <2.5%.
- 10.- The uncertainties of tests, which are made explicit in the Results Report, have been estimated for a $k = 2$ (95% probability of coverage). If not informed, they are available to the client in AITEX.
11. - The original materials and rests of samples, not subject to test, will be retained in AITEX during the twelve months following the issuance of the report, so that any check or claim which, in his case, wanted to make the applicant, should be exercised within the period indicated.
- 12.- This report may only be sent or delivered by hand to the applicant or to a person duly authorised by the same.
- 13.- The results of the tests and the statement of compliance with the specification in this report refer only to the test sample as it has been analyzed / tested and not the sample / item which has taken the test sample.
- 14.- The client must attend at all times, to the dates of the realization of the tests.
- 15.- According to Resolution EA (33) 31, the test reports must include the unique identification of the sample, and any brand or label of the manufacturer may be added. It is not allowed to re-issue test reports of untested sample names (references), they can only be re-issued for error correction or inclusion of omitted data that were already available at the time of the test. The laboratory can not assume responsibility for declaring that the product with the new trade name / trademark is strictly identical to the one originally tested; This responsibility belongs to the client.
- 16.- This report may not be partially reproduced without the written approval of the issuing laboratory.
- 17.- AITEX laboratories do not carry out sampling, so that the results of the test reports are applicable to the sample as it was received.